

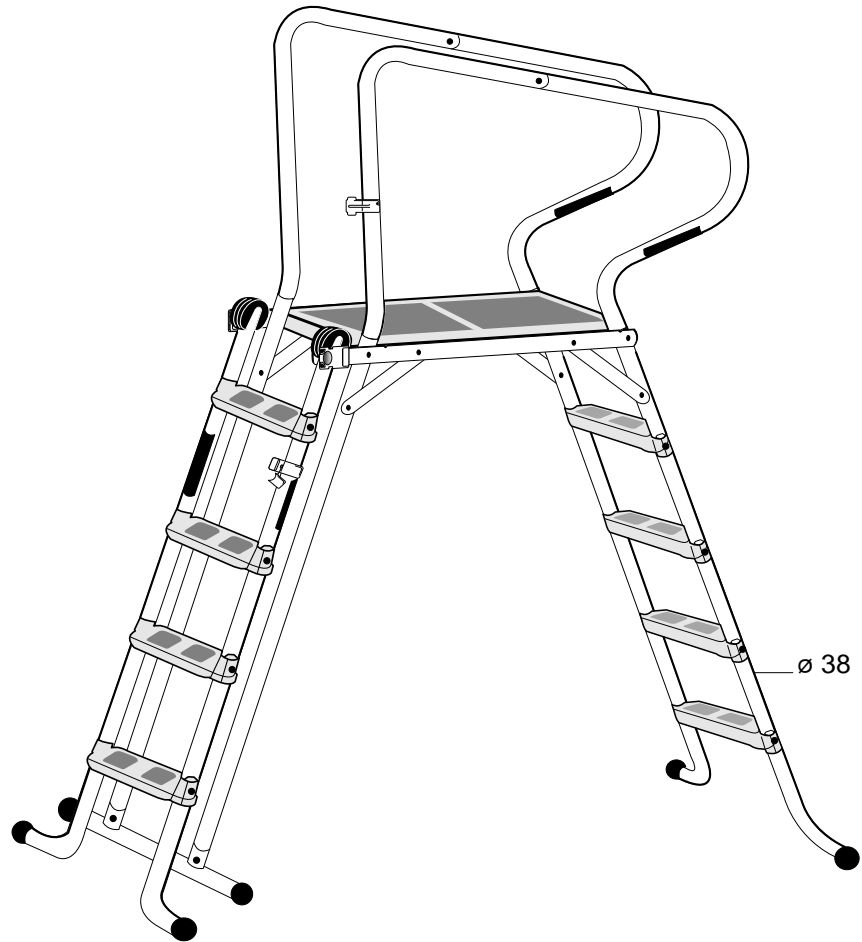

ZODIAC

L 142 / 8PSL



Notice d'instruction
Échelle

Owner's manual
Ladder

Installationsanleitung
Leitern

Istruzioni di montaggio
Scale

Manual del usuario
Escalera

Installatie handleiding
Trappen

Instruções de montagem
Escadas

Notice à conserver

Please keep these
instructions for further use

Bitte bewahren sie diese anleitung
für eine spätere benutzung auf

Manuale da conservare per un uso
ulteriore

Manual a coservar para cualquier
uso posterior

Bewaar de handleiding om later te
kunnen naslaan

Manual a guardar par fururas
consultas

N° : P20367

01.06

- F** Les coordonnées du fabricant et de ses filiales figurent sur la notice de la garantie du produit.
- I** Il recapito del fabbricante e delle sue filiali figurano sul manuale di garanzia del prodotto
- NL** De adresgegevens van fabrikant en filialen staan vermeld op het garantiebewijs van het product
- E** Los datos de contacto del fabricante y de sus filiales figuran en la información sobre la garantía del producto
- D** Die Koordinaten des Herstellers und seiner Tochtergesellschaften stehen auf dem Garantie-Heft des Produkts
- GB** The coordinates of the manufacturer and of its subsidiaries can be found on the warranty leaflet of the product

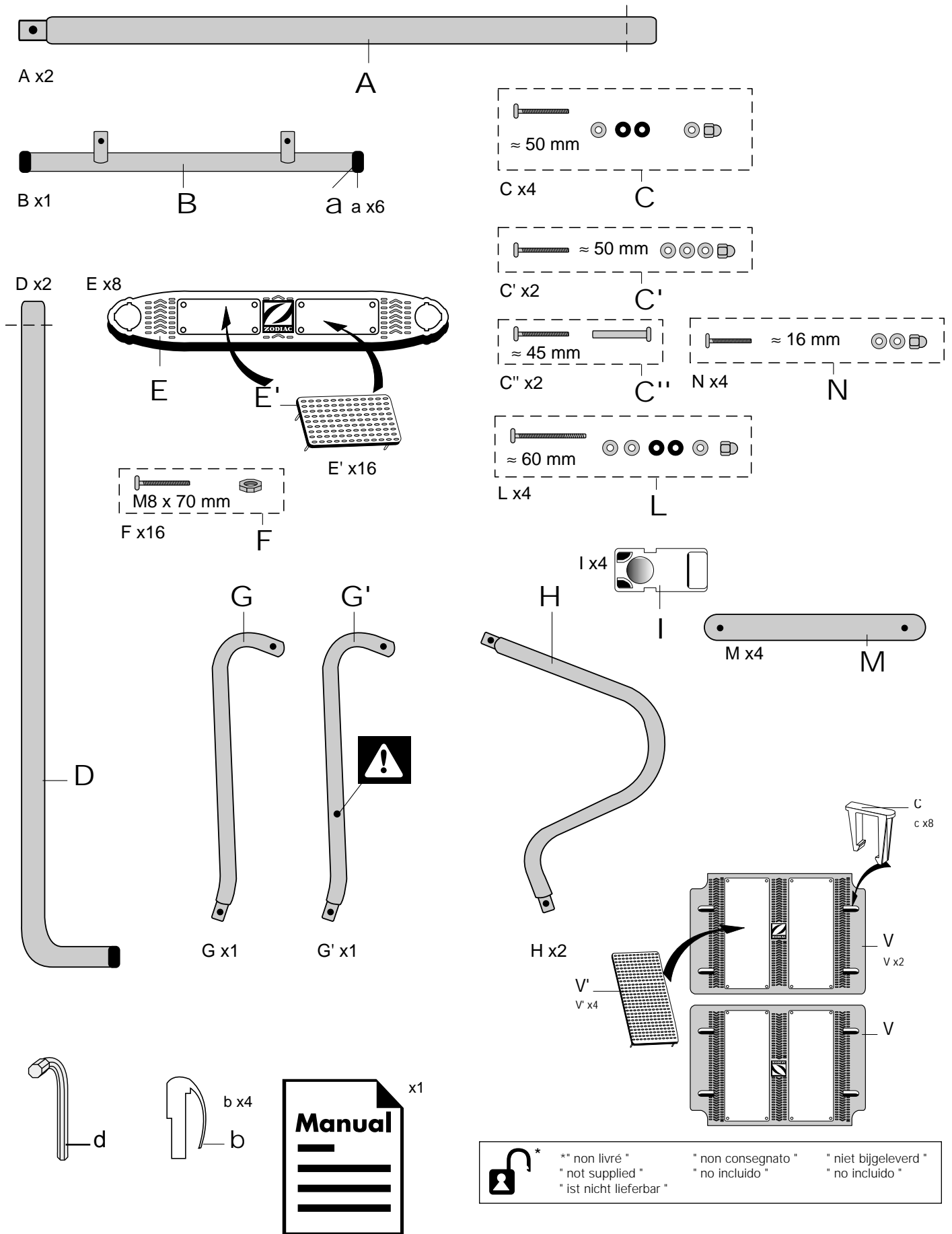

 ** non livré
 "not supplied"
 "ist nicht lieferbar"

"non consegnato"
 "no incluido"
 "no incluido"

"niet bijgeleverd"
 "no incluido"

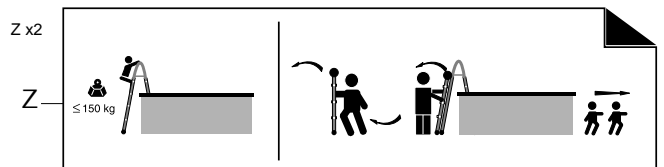
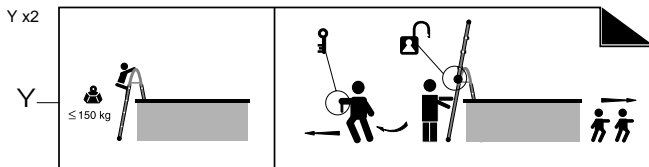
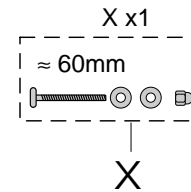
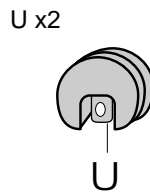
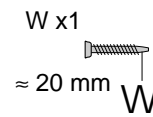
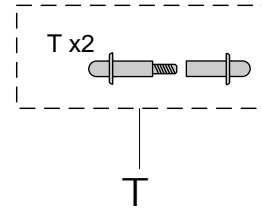
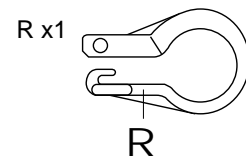
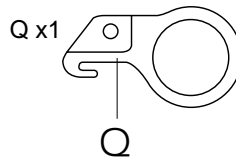
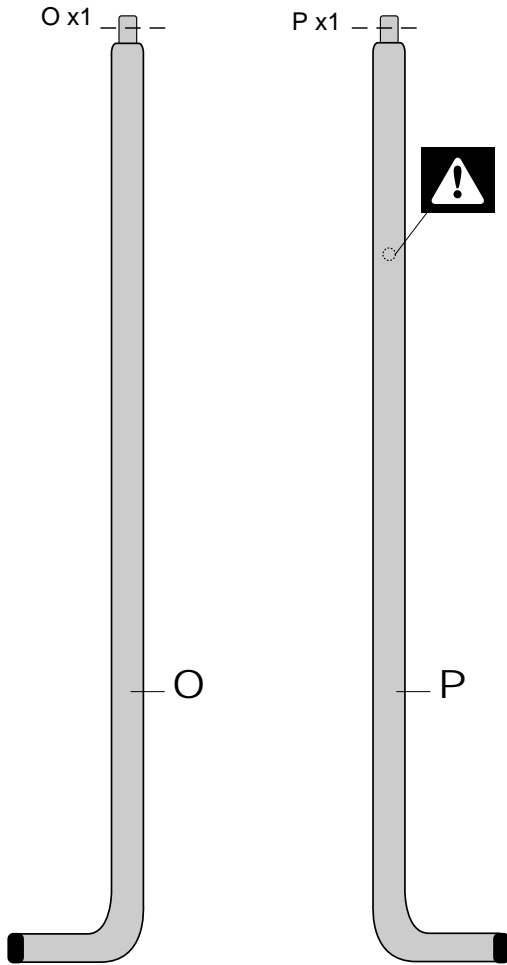
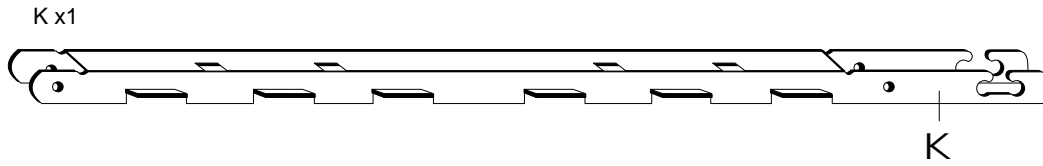
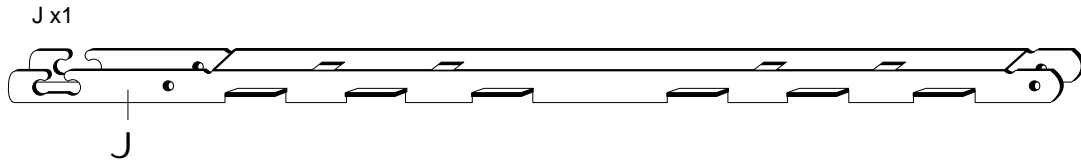

A...../	G - G'...../	M...../	S...../	Y.....P61323
B...../	H...../	N...../	T.....P61337	Z.....P61324
C - C'...../	I.....P61334	O...../	U.....P61338	a.....P61340
D...../	J...../	P...../	V + V'.....P61371	b.....P61339
E + E'.....P61823	K...../	Q.....P61335	W...../	c.....P61749
F.....P61824	L...../	R.....P61336	X...../	d...../

P61579 = 6xC + 2xC' + 4xL + 4xN + X + W

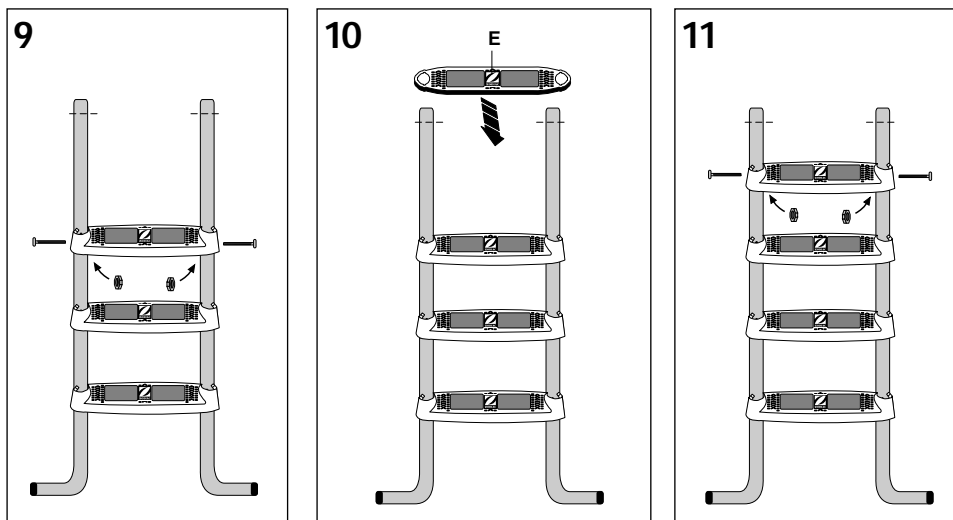
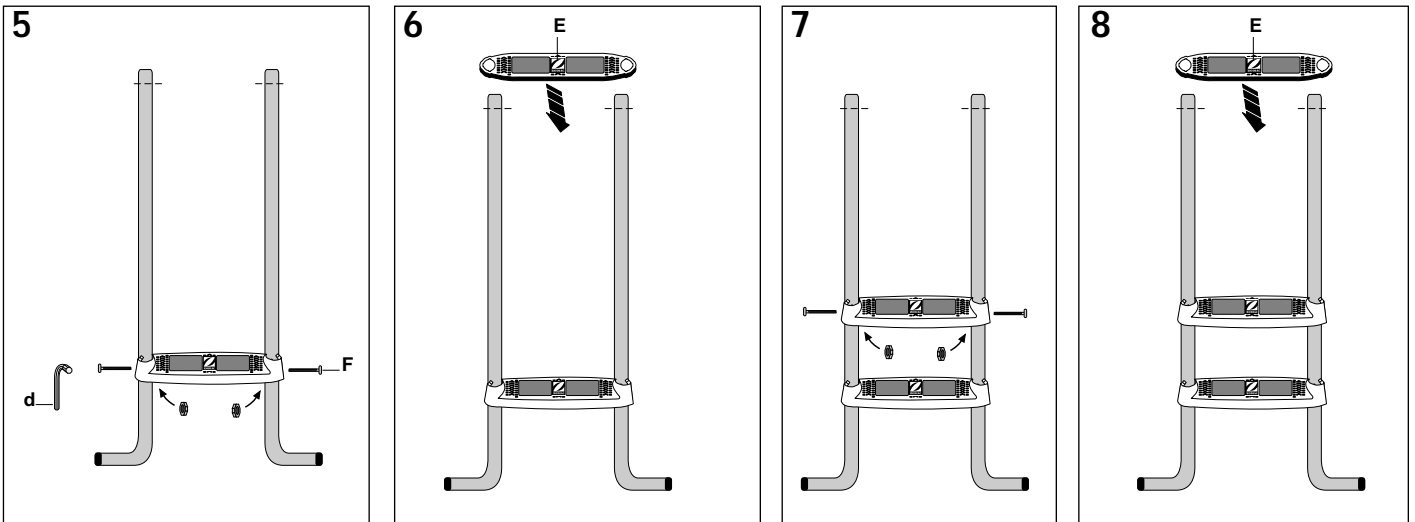
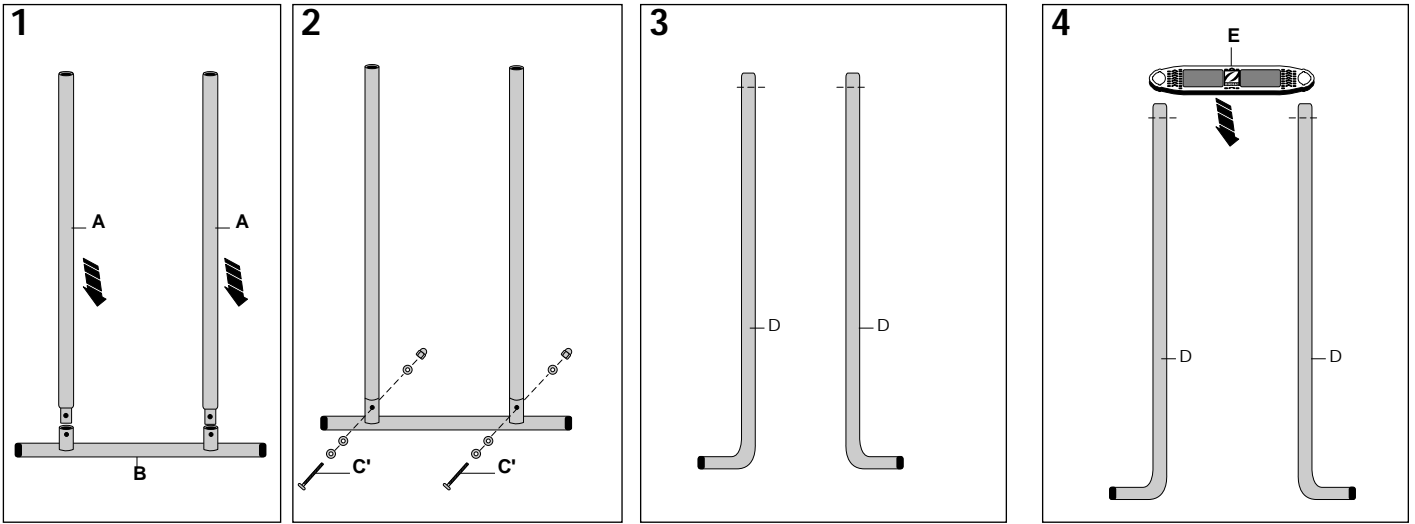

12

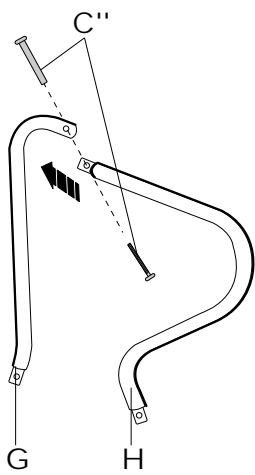

13

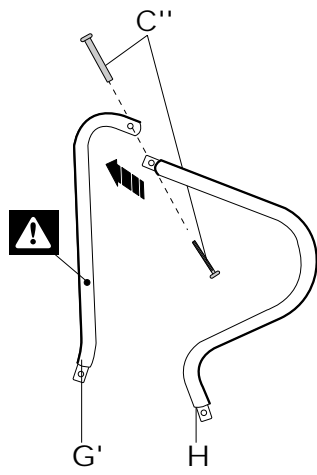

14

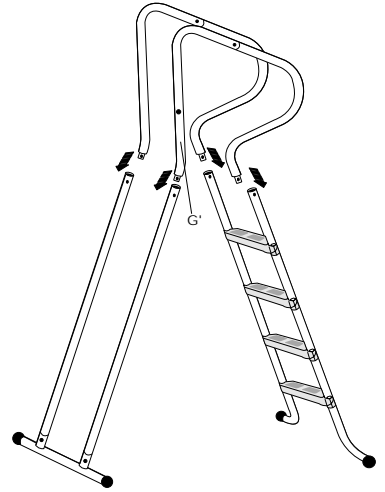

15

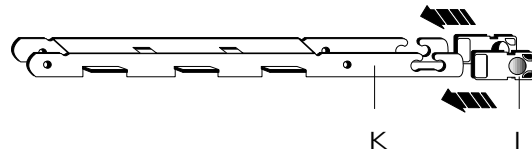
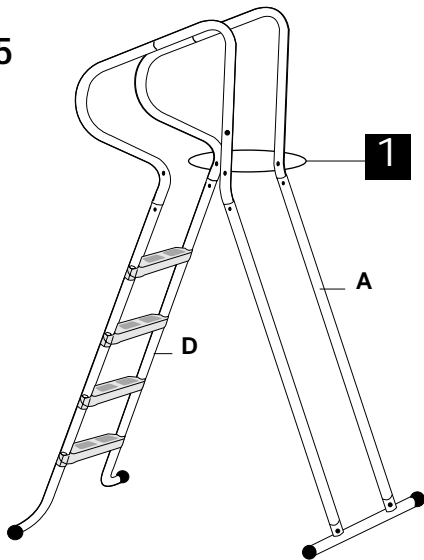

1

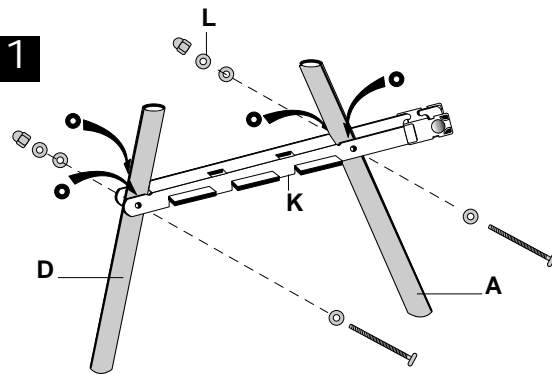

16

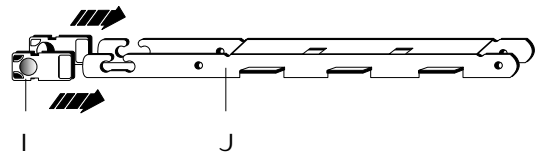
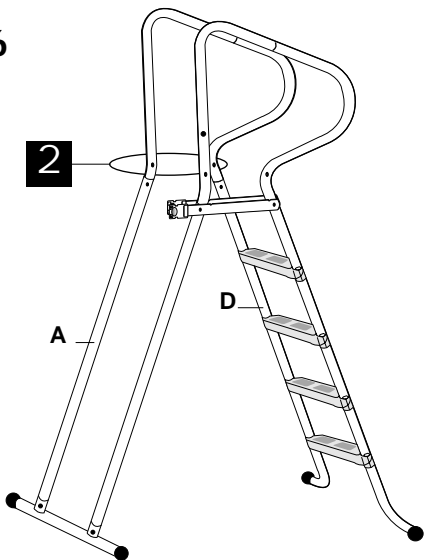

2

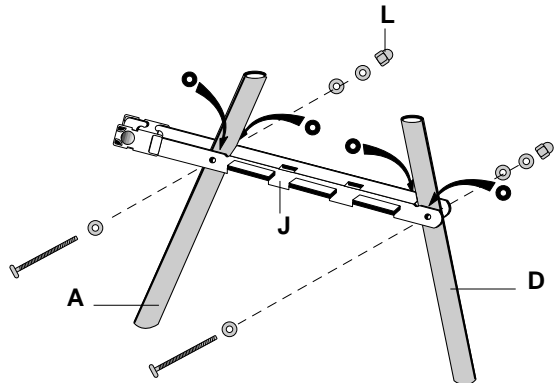

17

17 x4

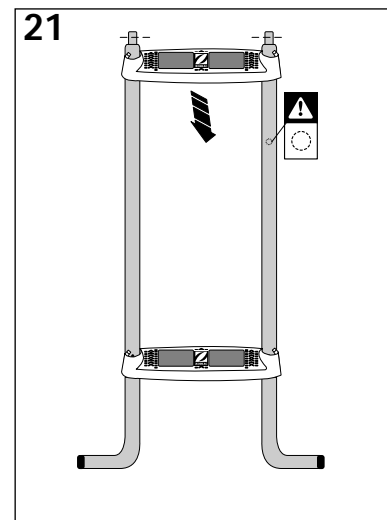
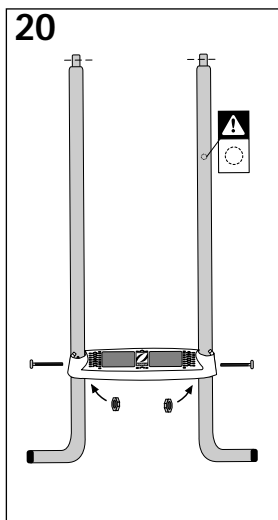
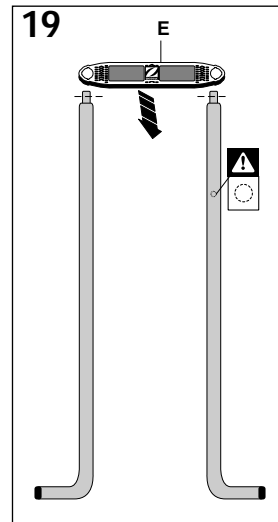
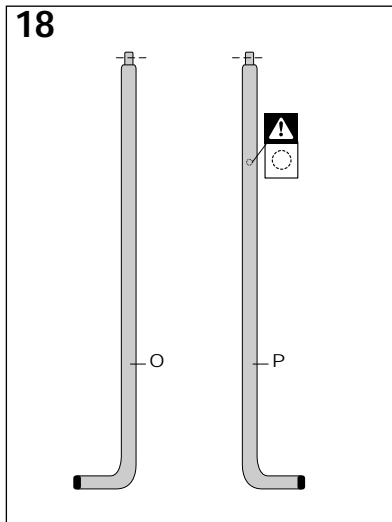
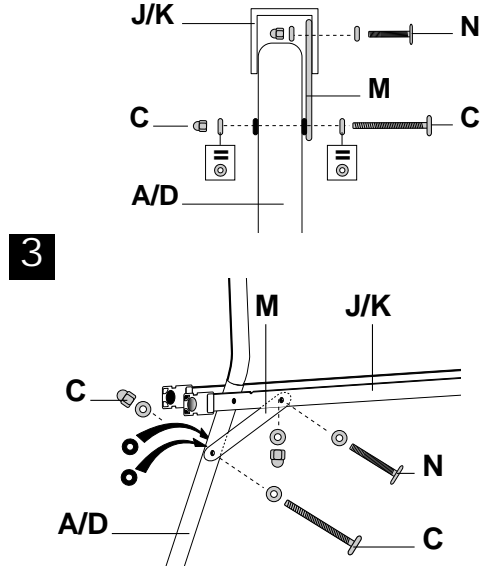
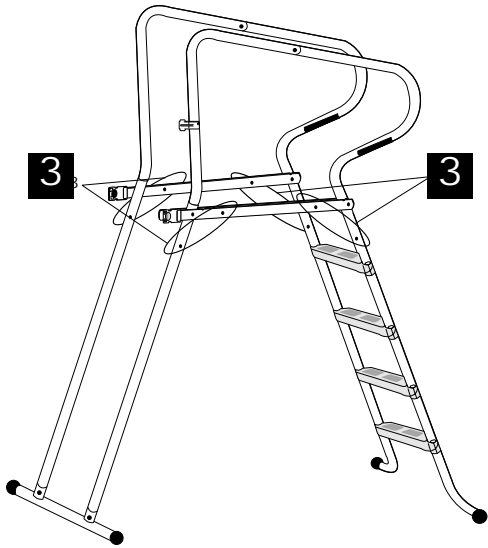

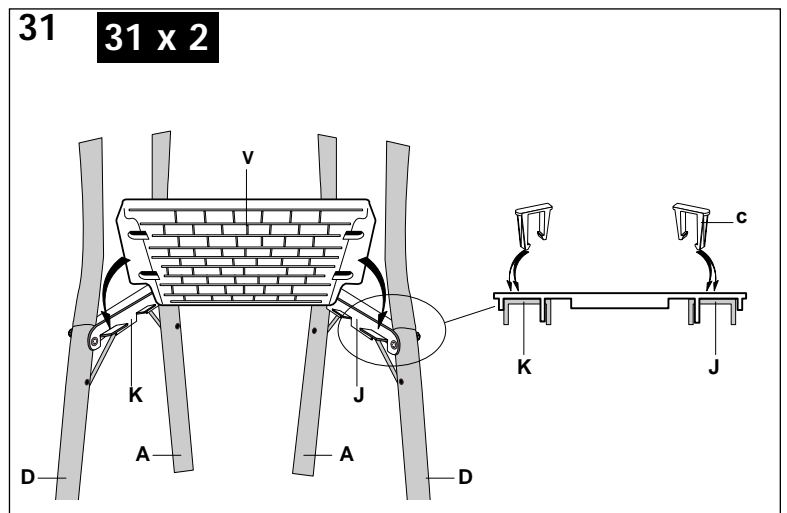
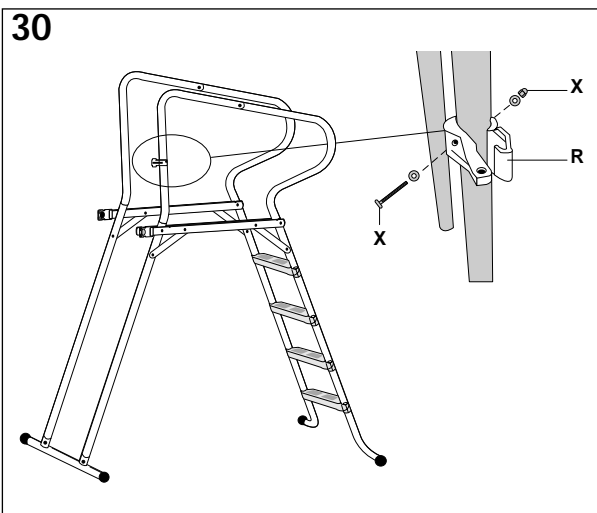
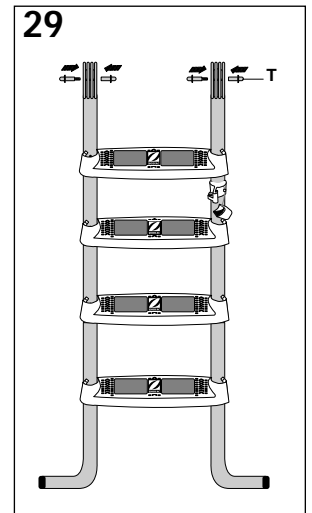
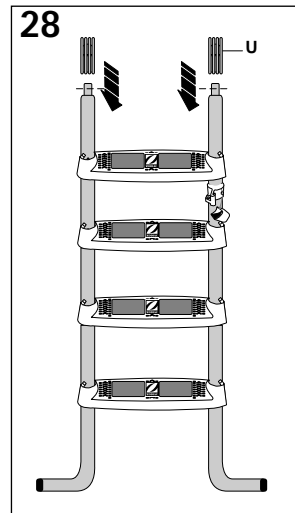
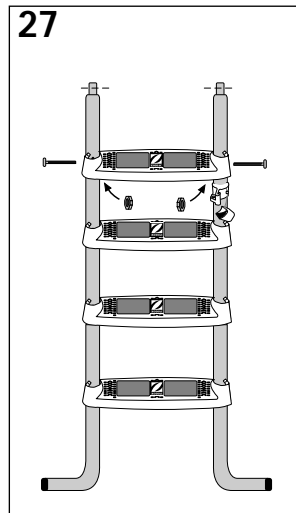
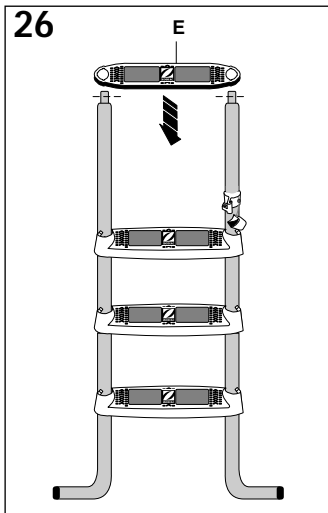
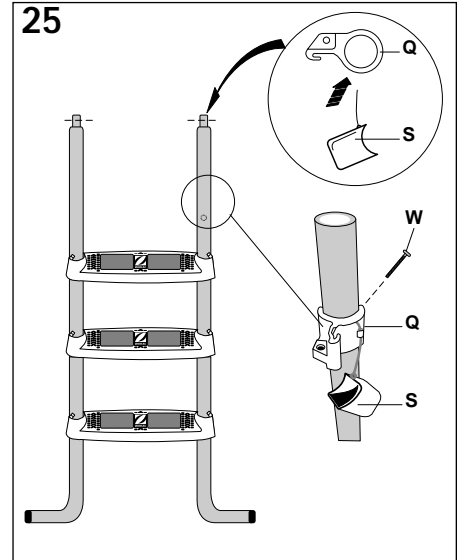
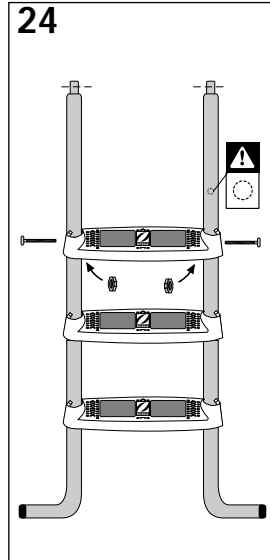
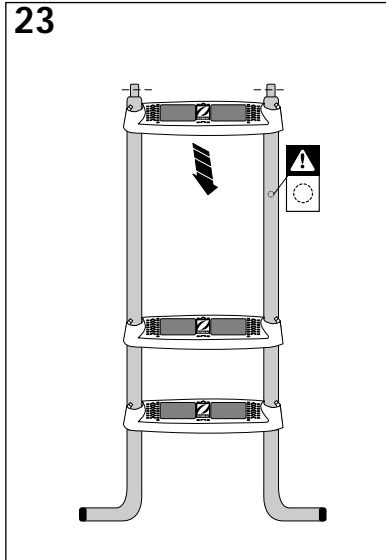
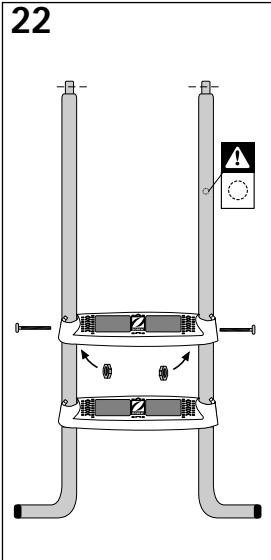

32

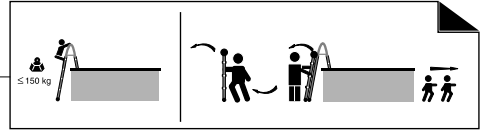
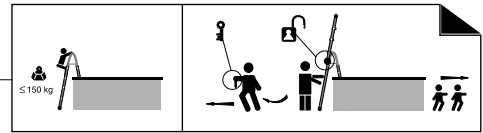
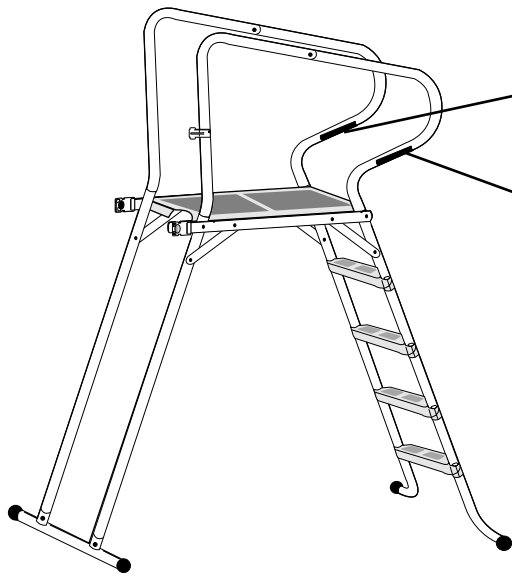

OK

33

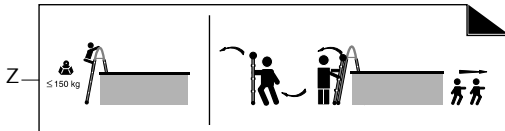

OK

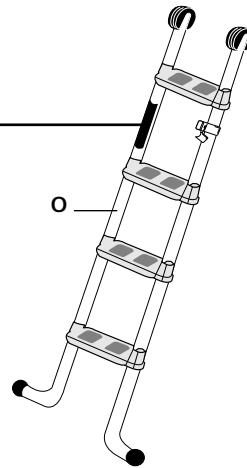

34

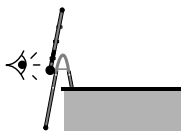
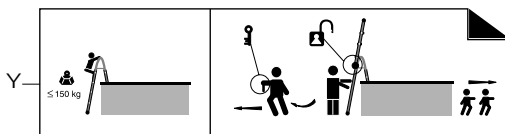

OK

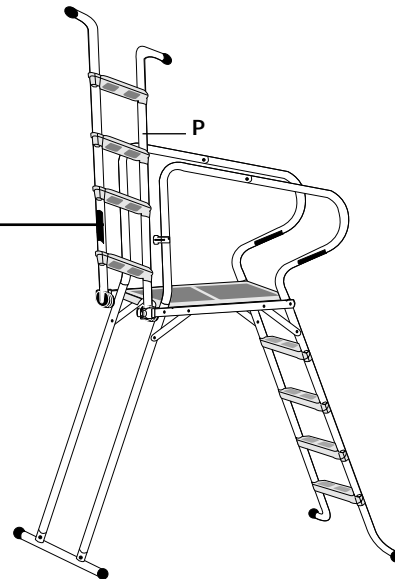

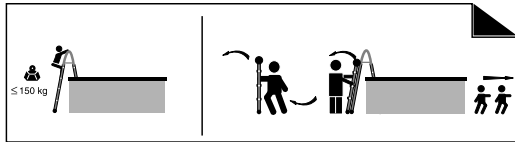
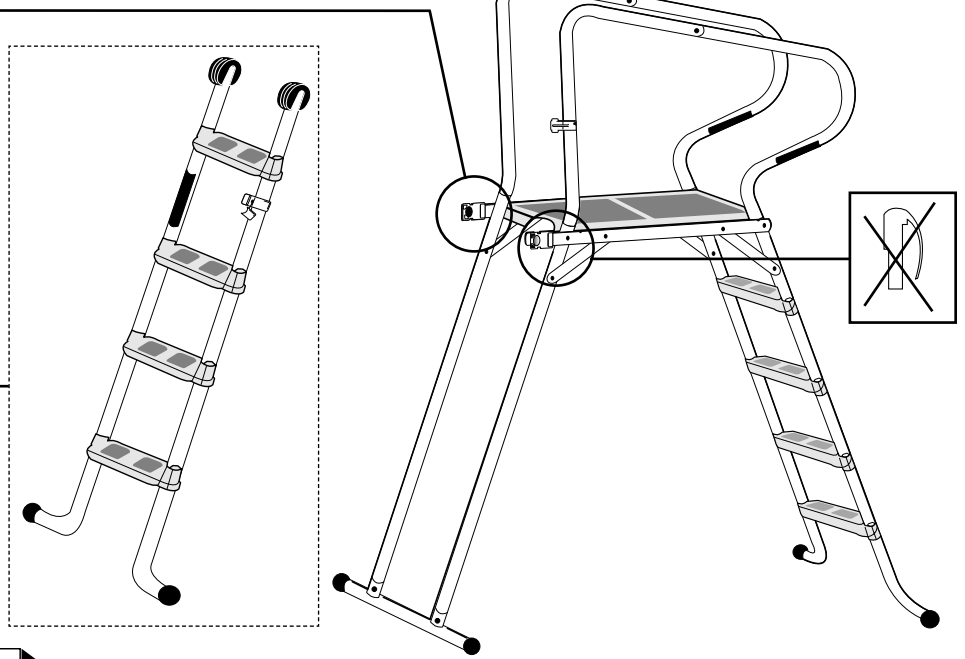
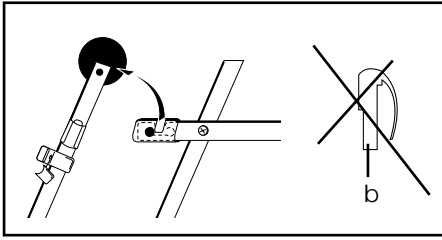

ou / or / o

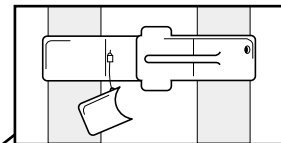
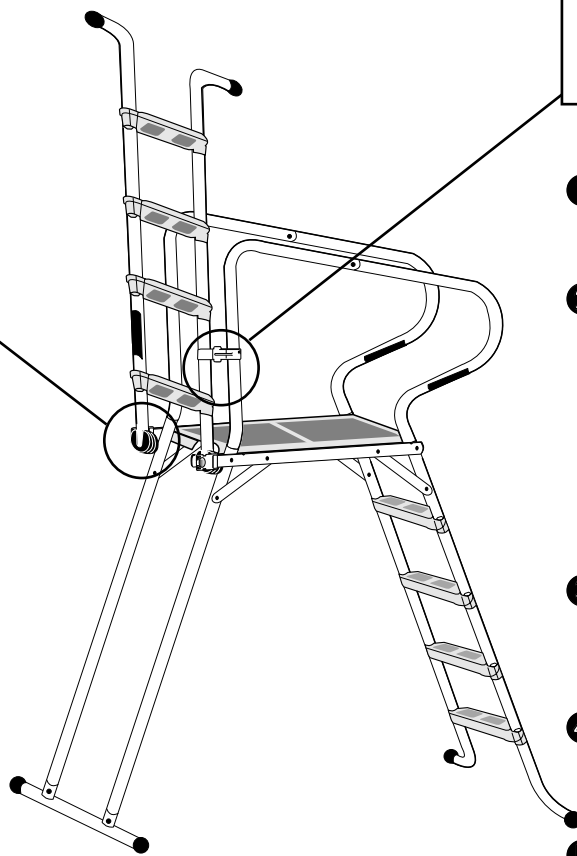
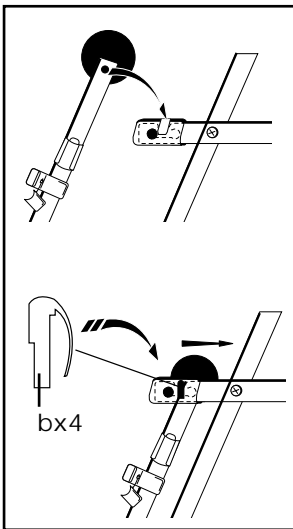

- 1
- 2
- 3
- 4
- 5

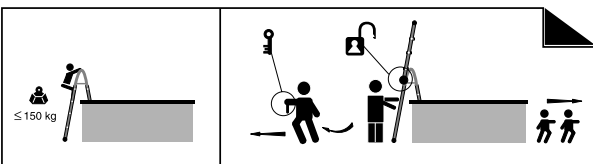

* " non livré " " non consegnato " " niet bijgeleverd "
 " not supplied " " no incluido " " no incluido "
 " ist nicht lieferbar "

F

Échelles dont l'usage est exclusivement réservé aux piscines hors sol. Échelle hauteur utile 142 cm pour piscine hors sol de hauteur 142 cm.

Conseils : il est conseillé de démonter et de nettoyer l'échelle pendant l'hiver afin de la conserver plus longtemps. Nos échelles standards sont fabriquées à partir d'un tube d'acier galvanisé à chaud recouvert d'une peinture anti-rouille appliquée électrostatiquement. Leur entretien ne respecte aucune règle précise, ni dans leur utilisation, ni dans le temps. Cependant, pendant et après chaque saison, un contrôle visuel est nécessaire. Si vous constatez des points de rouille, il faut y remédier en appliquant une peinture anti-rouille. Les précautions à y apporter sont en général mentionnées sur le pot de celle-ci. Nous nous réservons le droit de modifier totalement ou en partie les caractéristiques de nos articles ou le contenu de ce document sans préavis.

Impératif : pour des raisons de sécurité, retirez ou relevez et cadenassez l'échelle (c) (accès à la piscine) quand celle-ci n'est pas en service.

GB

The use of this ladder is exclusively reserved to onground swimming pools. Ladder with a useful height of 142 cm for onground swimming pools with a height of 142 cm.

Tips : it is recommended to take off and clean the ladder during winter time to preserve it for a long period of time. Our ladders are manufactured with electrostatic painted steel tubing, which provides a rust protection. Their use condition and maintenance method are up to the owner. During and after swimming season, a visual inspection is required. If you encounter rust stains, treat them with anti-rust product. Treatment conditions are specified with anti-rust product. We can modify this product characteristics or this manual content without previous notice.

Imperative: for safety reasons, remove, or lift up and padlock the ladder (c) (access to the swimming pool) when the pool is not in use

D

Leitern für eine ausschließliche Benutzung mit auf dem Boden aufgestellten Schwimmbecken. Nutzhöhe 142 cm für auf dem Boden aufgestellte Schwimmbecken mit einer Höhe von 142 cm.

Hinweise: für die Lebensdauer der Leiter ist es angeraten, diese vor dem Winter zu demontieren und zu reinigen. Unsere Standard-Leitern werden aus Stahlrohr hergestellt und mit einer elektrostatisch aufgetragenen Rostschutzfarbe geschützt.

Es gibt keine genauen Wartungs-Regeln, weder hinsichtlich der Benutzung noch hinsichtlich der Dauer. Während und am Ende der Saison eine Sichtkontrolle durchführen. Stellen Sie Rostpunkte fest, so müssen diese mit Hilfe einer Rostschutzfarbe behandelt werden. Die zu treffenden Vorsichtsmaßnahmen sind im allgemeinen auf dem Farbtropf angegeben. Wir halten uns das Recht vor, die Eigenschaften unserer Artikel oder den Inhalt dieses Dokumentes in Gänze oder teilweise abzuändern.

Imperativ: Aus Sicherheitsgründen, oder hochklappen und mit einem Vorhängeschloss sichern die Leiter (c) (Zugang zum Becken) entfernen wenn dieses nicht in Betrieb ist.

I

Scale adatte esclusivamente a piscine di tipo fuori terreno. Scale di altezza utile 142 cm per piscina di tipo fuori terreno di altezza 142 cm.

Suggerimenti : è opportuno smontare e pulire la scala durante la stagione invernale per una maggiore conservazione. Le nostre scale di tipo standard vengono prodotte sulla base di un tubo di acciaio ricoperto da pittura anti ruggine applicata con metodo elettrostatico.

La manutenzione non richiede nessuna attenzione particolare sia per quanto riguarda l'uso che la durata stessa. Occorre tuttavia verificare lo stato della pittura durante e al termine di ogni stagione. In presenza di ruggine, suggeriamo di intervenire con un prodotto anti ruggine. Le eventuali precauzioni d'uso vengono generalmente riportate sul barattolo stesso. Le caratteristiche dei nostri prodotti o il contenuto stesso del presente documento sono soggetti a possibili variazioni.

Attenzione: per motivi di sicurezza, è opportuno ritirare, o ribaltare verso l'alto e chiudere col lucchetto la scala (c) (accesso alla vasca) quando la piscina non viene utilizzata.

E

Escalera para uso exclusivo en piscinas sin enterrar. Escalera altura útil 142 cm para piscina sin enterrar de altura 142 cm.

Consejos : para que la escalera dure más tiempo, es aconsejable desmontarla y limpiarla durante el invierno. Nuestras escaleras están fabricadas a partir de un tubo de acero recubierto por una pintura antioxidante, aplicada electrostáticamente. Su conservación no se rige por ninguna regla precisa, ni por su uso, ni por el tiempo. Durante y después del periodo en el que se está utilizando, es necesario un control visual. Si se detectan puntos de óxido, es necesario combatirlos aplicando pintura antioxidante. Las precauciones a tomar están, generalmente, indicadas en las instrucciones de uso de la propia pintura. Nos reservamos el derecho a modificar, total o parcialmente, las características de nuestros productos o el contenido de este documento sin previo aviso.

Imperativo : por motivos de seguridad, retirar, o levantar y cerrar con un candado la escalera (c) (acceso a la piscina) cuando la piscina no está en servicio.

NL

Trappen voorbehouden voor gebruik bij bovengrondse zwembaden. Trap met nuttige hoogte 142 cm voor bovengronds zwembad met een hoogte van 142 cm.

Tips: het wordt aangeraden de trap voor de winter te demonteren en te reinigen met het oog op een langere levensduur. Onze standaard trappen zijn vervaardigd van stalen buis, bedekt met een elektrostatisch aangebrachte antiroest verf.

Voor het onderhoud bestaan geen precieze regels, in gebruik of tijd. Tijdens en na ieder seizoen is een visuele controle noodzakelijk. Als u roestplekjes vaststelt moeten deze bestreden worden met een antiroest verf. De te nemen voorzorgen worden in het algemeen op de verpot vermeld. We behouden ons het recht voor geheel of gedeeltelijk de kenmerken van onze artikelen of de inhoud van dit document te wijzigen.

Zeer belangrijk: om redenen van veiligheid moet, of oplichten en vergrendelen de trap (c) (toegang tot het bassin) worden verwijderd wanneer het zwembad niet gebruikt wordt.

P

Escadas cuja utilização é exclusivamente reservada a piscinas fora do solo. Escada altura necessária 142 cm para piscina fora do solo com uma altura de 142 cm.

Conselhos: convém desmontar e limpar a escada durante o Inverno para uma maior duração de vida. As nossas escadas padrão são fabricadas a partir de um tubo de aço coberto de uma pintura antiferrugem aplicada electro-estaticamente.

Não é preciso uma manutenção particular, nem na sua utilização, nem no tempo. Durante e após cada estação, é necessário um controlo visual. Se constatar pontos de ferrugem, será preciso remediar a esse problema aplicando uma pintura antiferrugem. As precauções de utilização são geralmente indicadas no frasco da mesma. Reservamo-nos o direito de modificar totalmente ou em parte as características dos nossos artigos e o conteúdo deste documento.

Obrigatório: por medida de segurança, é favor tirar, ou levantar e fechar com cadeado a escada (c) (acesso à piscina), quando a piscina não está a ser utilizada

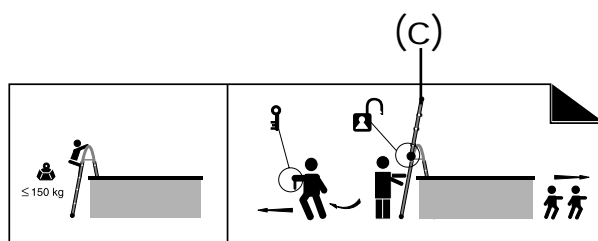
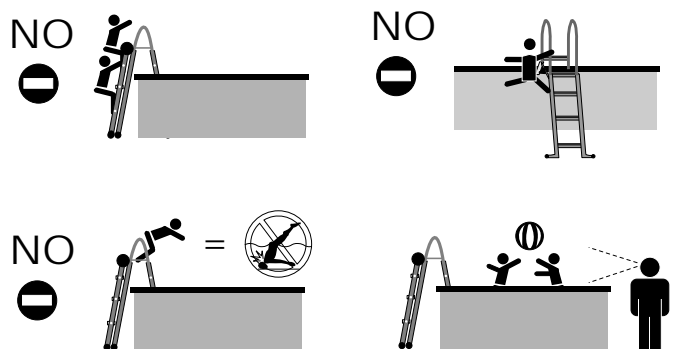

ou
or
o

